

USB



File: USB.kicad_sch
SFP



File: SFP.kicad_sch

Power



File: Power.kicad_sch

Ethernet

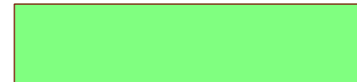

File: Ethernet.kicad_sch

Clock-WR

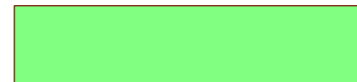

File: clocks.kicad_sch

FPGA



File: FPGA.kicad_sch

MGT

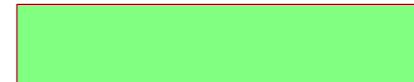

File: MGT.kicad_sch

FPGA_PWR

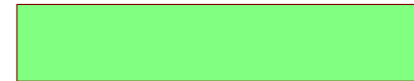

File: FPGA_PWR.kicad_sch

FPGA_MISC



File: FPGA_MISC.kicad_sch

DDR

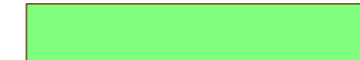

File: DDR.kicad_sch

PMODs

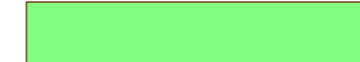

File: PMODs.kicad_sch

Arduino



File: Arduino.kicad_sch

B1 B2 B3 B4
⊗ ⊗ ⊗ ⊗

Michal Gaska		
Obsidian		
Sheet: /		
File: Obsidian.kicad_sch		
Title:		
Size: A3	Date: 2025-04-18	Rev: 1.1.0
KiCad E.D.A. 9.0.7		Id: 1/13

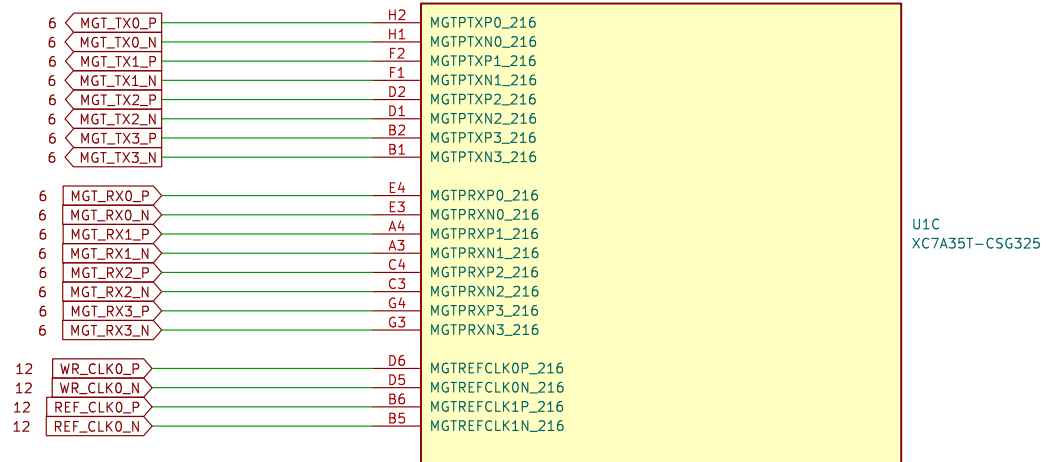

Michal Gaska
Obsidian
 Sheet: /MGT/
 File: MGT.kicad_sch

Title:	
Size: A4	Date: 2025-04-18
KiCad E.D.A. 9.0.7	Rev: 1.1.0
	Id: 3/13

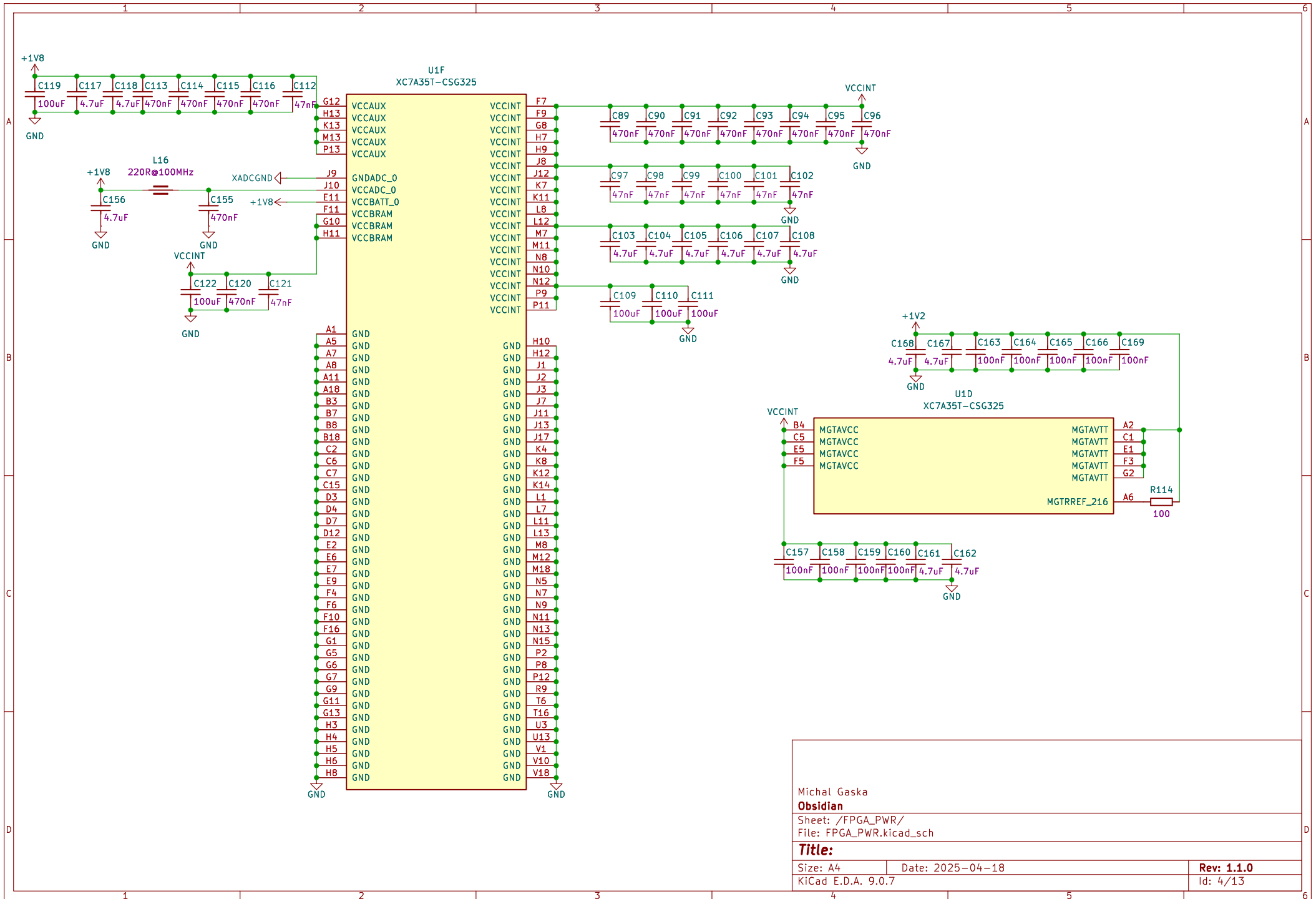

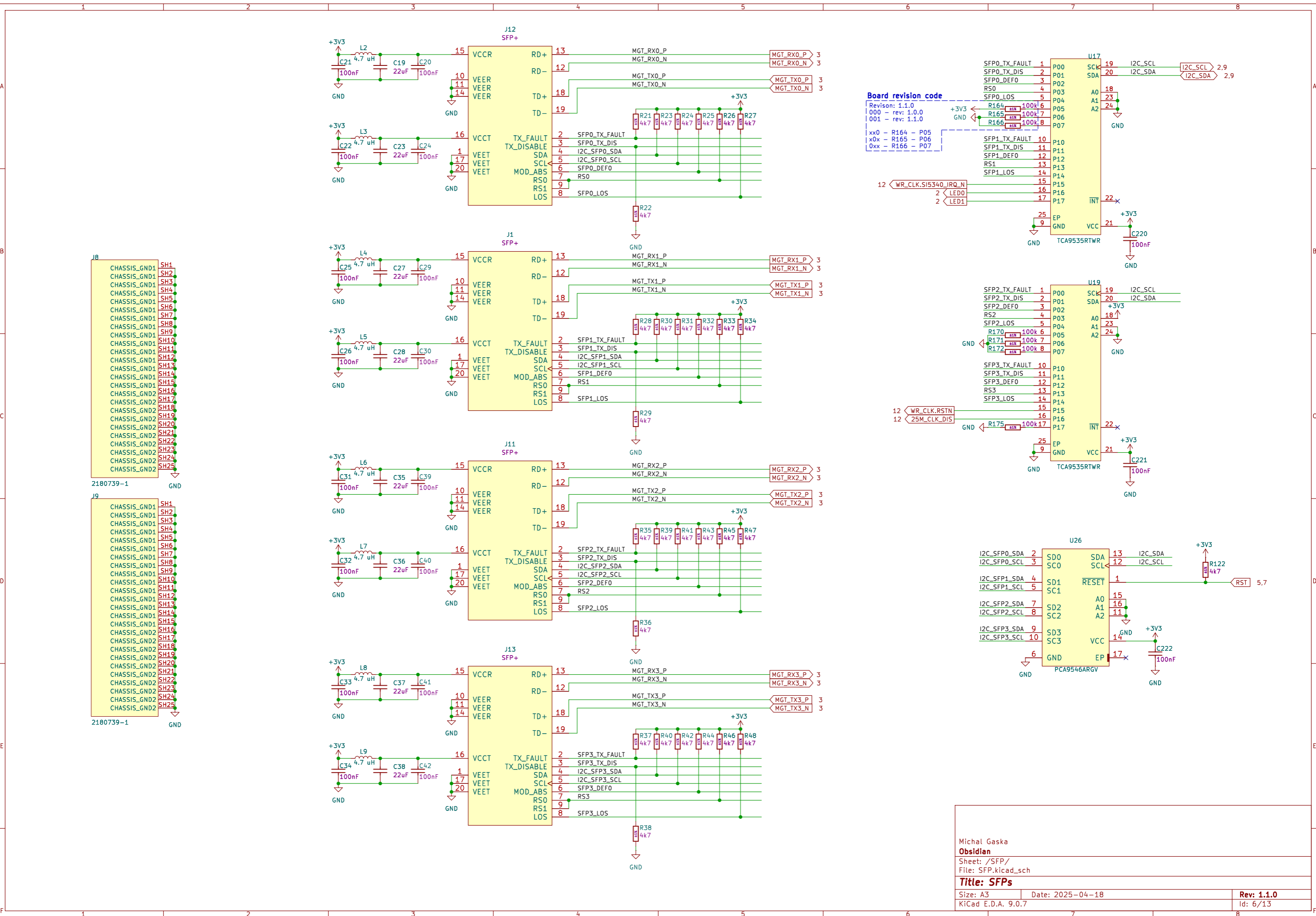

J8

CHASSIS_GND1	SH1
CHASSIS_GND1	SH2
CHASSIS_GND1	SH3
CHASSIS_GND1	SH4
CHASSIS_GND1	SH5
CHASSIS_GND1	SH6
CHASSIS_GND1	SH7
CHASSIS_GND1	SH8
CHASSIS_GND1	SH9
CHASSIS_GND1	SH10
CHASSIS_GND1	SH11
CHASSIS_GND1	SH12
CHASSIS_GND1	SH13
CHASSIS_GND1	SH14
CHASSIS_GND1	SH15
CHASSIS_GND2	SH16
CHASSIS_GND2	SH17
CHASSIS_GND2	SH18
CHASSIS_GND2	SH19
CHASSIS_GND2	SH20
CHASSIS_GND2	SH21
CHASSIS_GND2	SH22
CHASSIS_GND2	SH23
CHASSIS_GND2	SH24
CHASSIS_GND2	SH25

2180739-1

J9

CHASSIS_GND1	SH1
CHASSIS_GND1	SH2
CHASSIS_GND1	SH3
CHASSIS_GND1	SH4
CHASSIS_GND1	SH5
CHASSIS_GND1	SH6
CHASSIS_GND1	SH7
CHASSIS_GND1	SH8
CHASSIS_GND1	SH9
CHASSIS_GND1	SH10
CHASSIS_GND1	SH11
CHASSIS_GND1	SH12
CHASSIS_GND1	SH13
CHASSIS_GND1	SH14
CHASSIS_GND1	SH15
CHASSIS_GND1	SH16
CHASSIS_GND2	SH17
CHASSIS_GND2	SH18
CHASSIS_GND2	SH19
CHASSIS_GND2	SH20
CHASSIS_GND2	SH21
CHASSIS_GND2	SH22
CHASSIS_GND2	SH23
CHASSIS_GND2	SH24
CHASSIS_GND2	SH25

2180739-1

Board revision code

Revision: 1.1.0
 000 - rev: 1.0.0
 001 - rev: 1.1.0

xx0 - R164 - P05
 x0x - R165 - P06
 0xx - R166 - P07

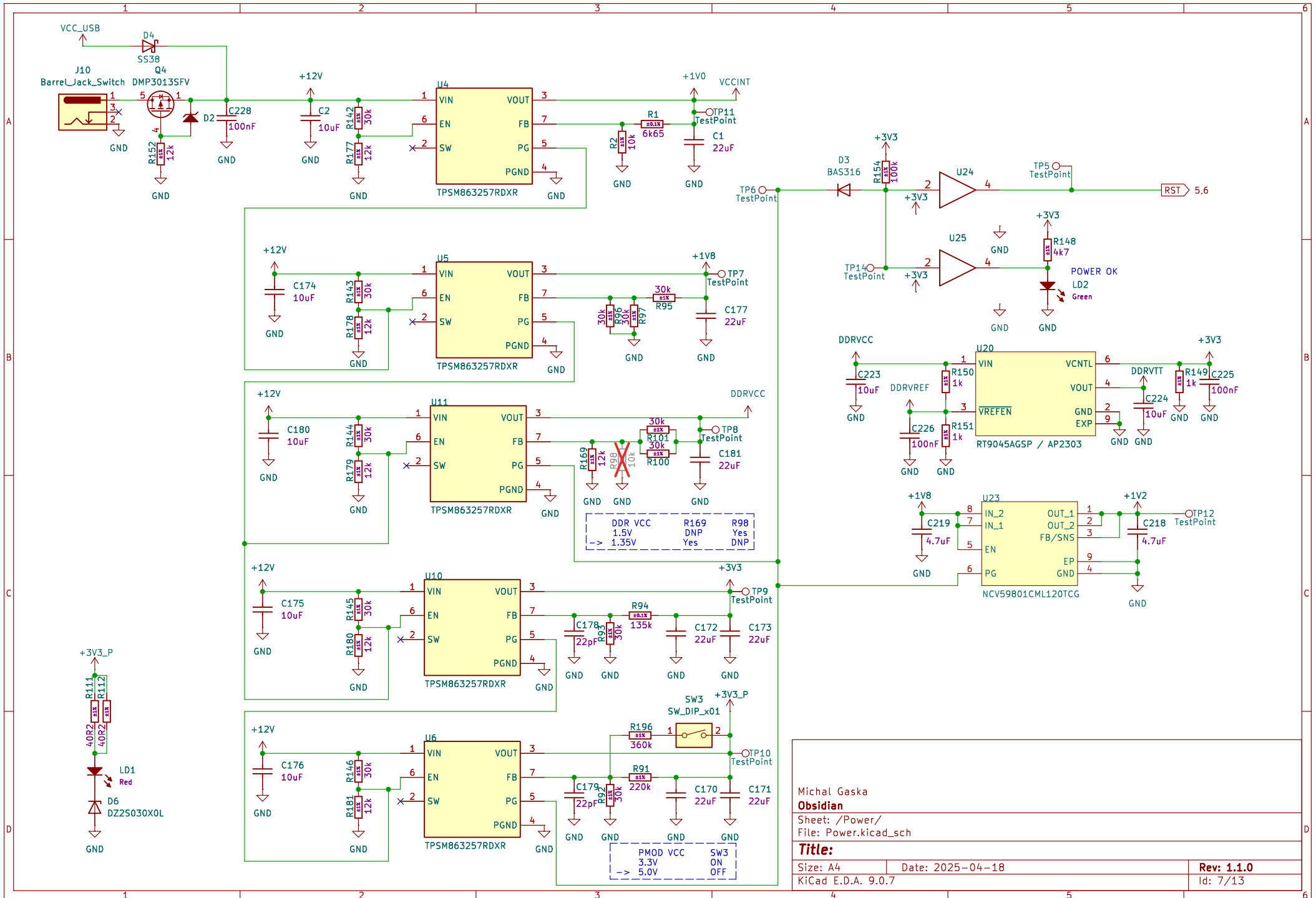

Michal Gaska Obsidian Sheet: /Power/ File: Power.kicad_sch	
Title:	
Size: A4	Date: 2025-04-18
KiCad E.D.A. 9.0.7	Rev: 1.1.0 Id: 7/13

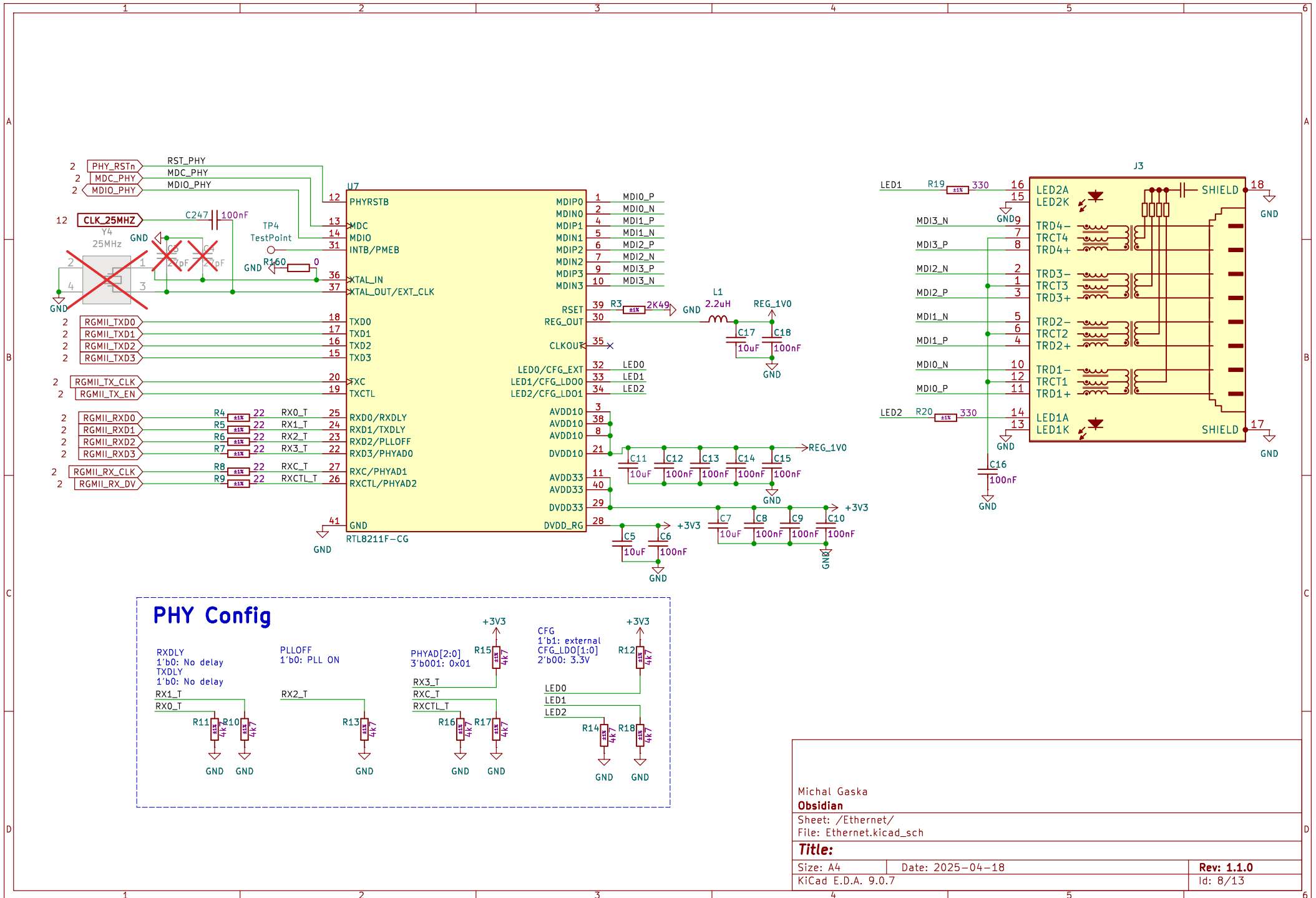

Michal Gaska
Obsidian

Sheet: /Ethernet/
File: Ethernet.kicad_sch

Title:

Size: A4
KiCad E.D.A. 9.0.7

Date: 2025-04-18

Rev: 1.1.0
Id: 8/13

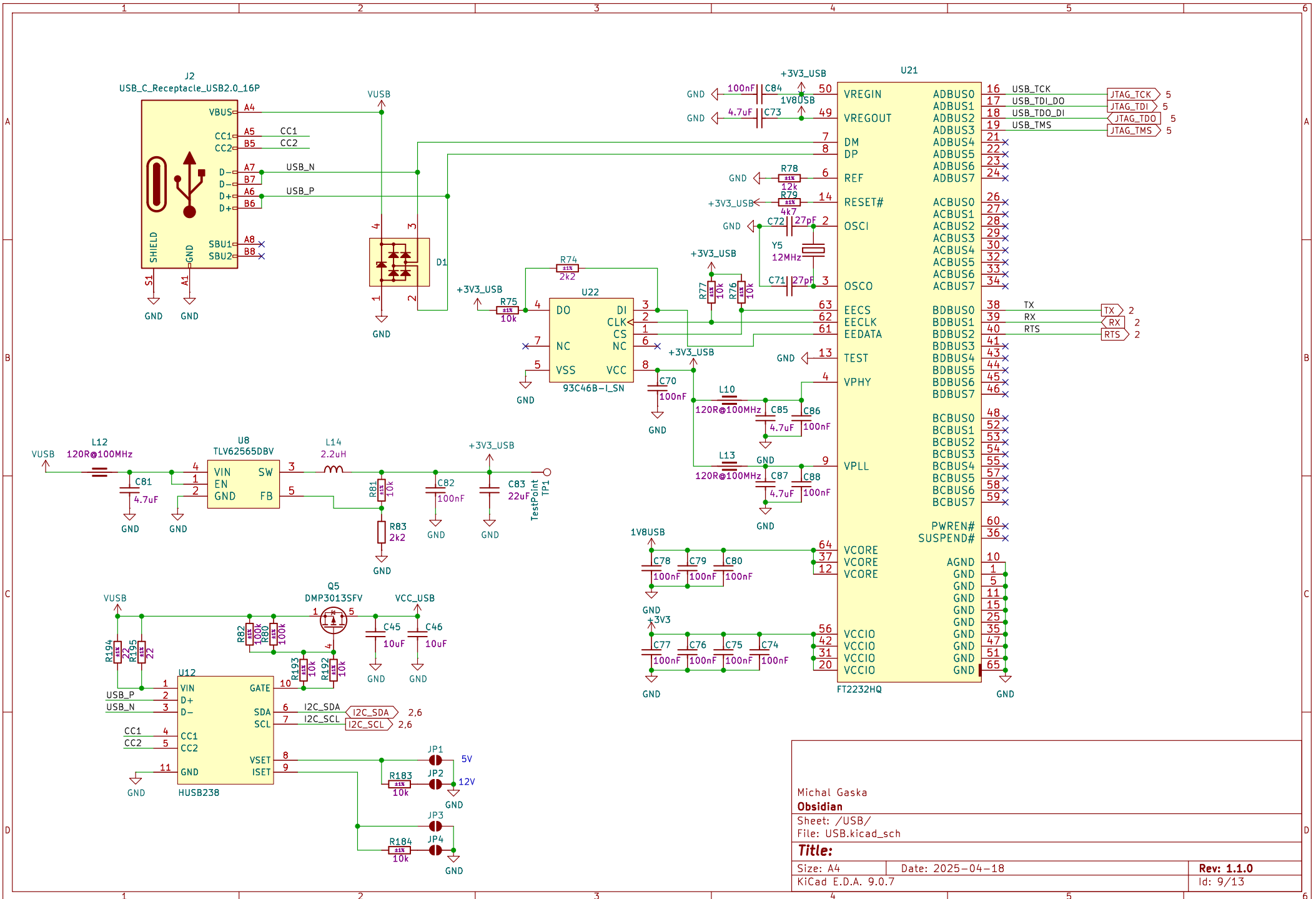

Michal Gaska		
Obsidian		
Sheet: /USB/		
File: USB.kicad_sch		
Title:		
Size: A4	Date: 2025-04-18	Rev: 1.1.0
KiCad E.D.A. 9.0.7		Id: 9/13

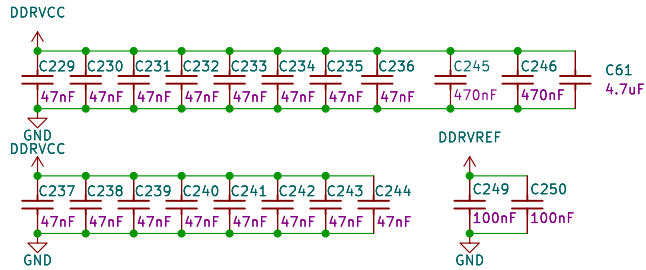
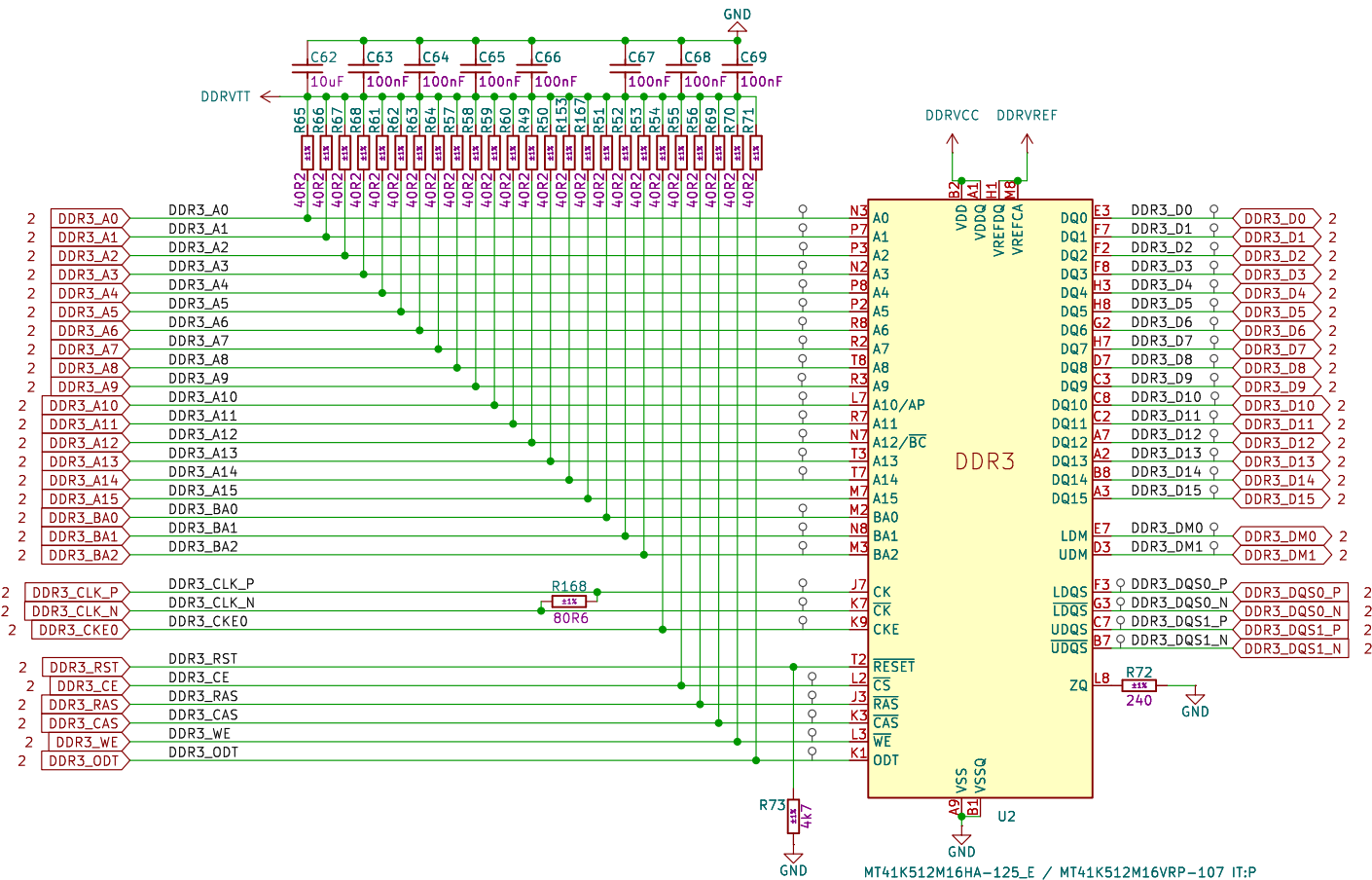

Michal Gaska		Obsidian	
Sheet: /DDR/		DDR3_A15 2	
File: DDR.kicad_sch			
Title:			
Size: A4	Date: 2025-04-18	Rev: 1.1.0	
KiCad E.D.A. 9.0.7			Id: 10/13

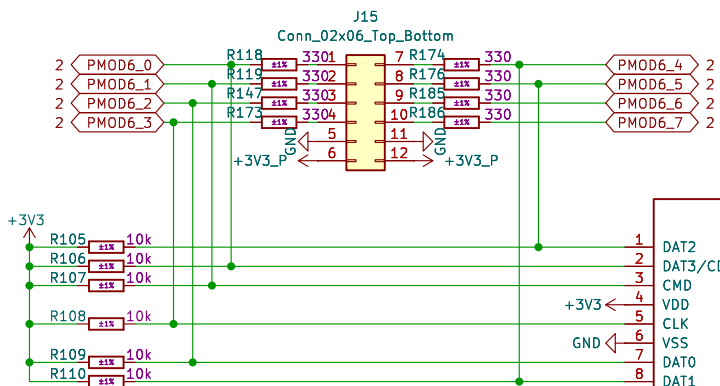
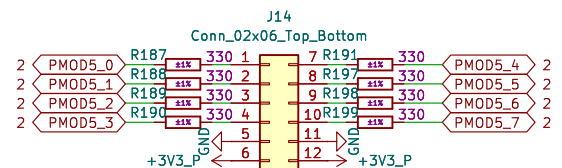
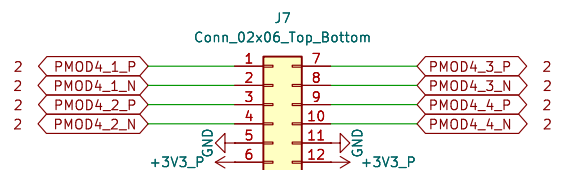
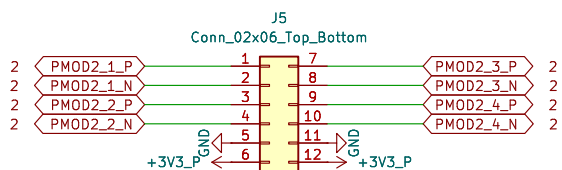
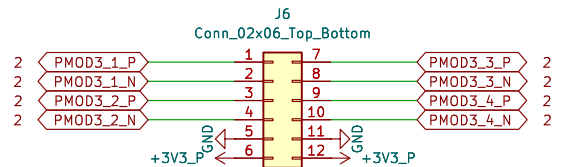
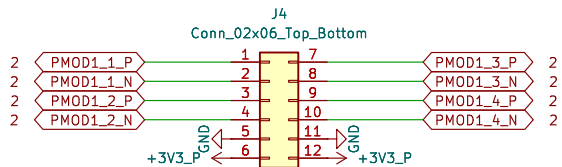

Michal Gaska
Obsidian

Sheet: /PMODs/
File: PMODs.kicad_sch

Title:

Size: A4 Date: 2025-04-18
KiCad E.D.A. 9.0.7

Rev: 1.1.0
Id: 11/13

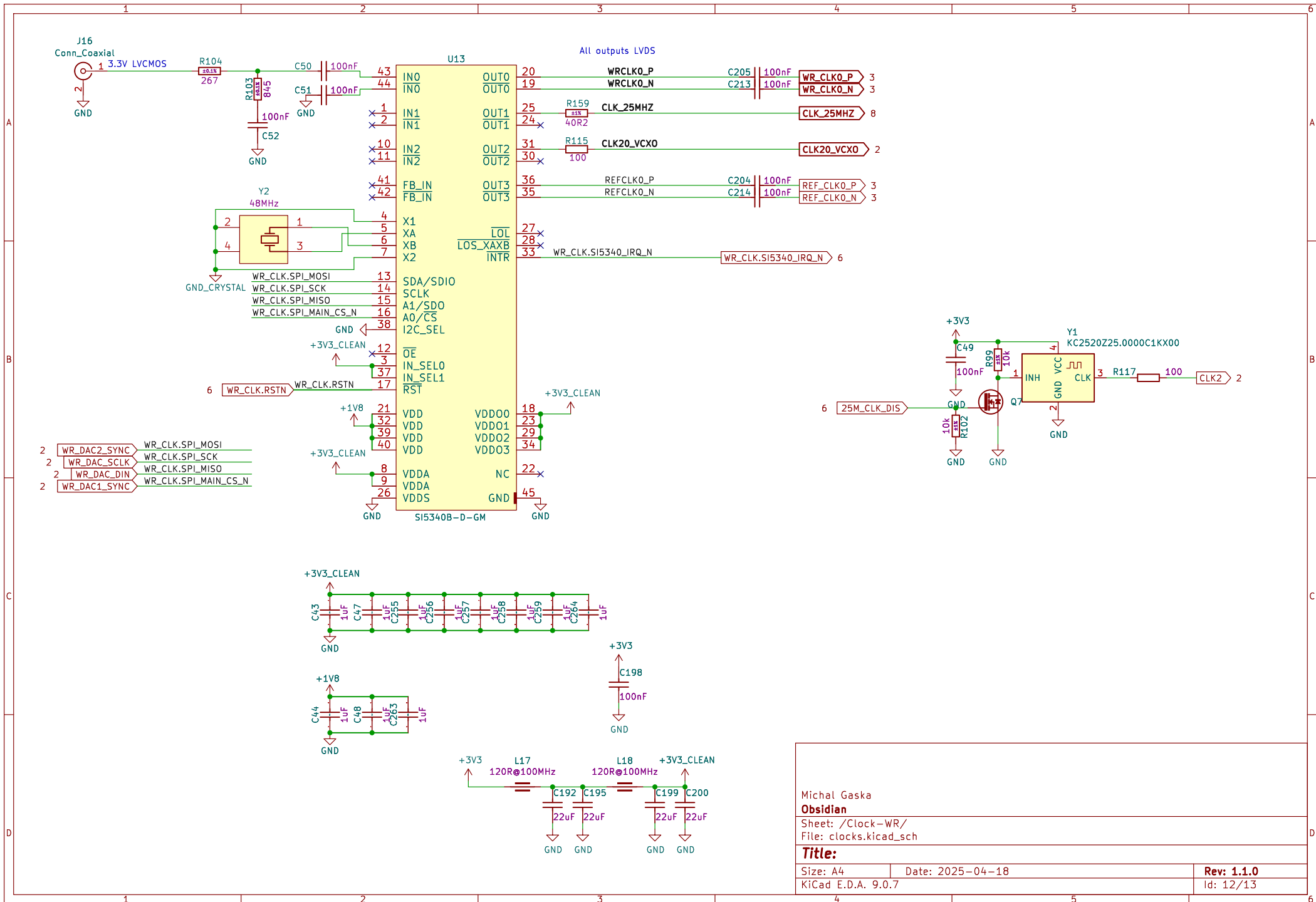

Michal Gaska	
Obsidian	
Sheet: /Clock-WR/	
File: clocks.kicad_sch	
Title:	
Size: A4	Date: 2025-04-18
KiCad E.D.A. 9.0.7	Rev: 1.1.0
	Id: 12/13

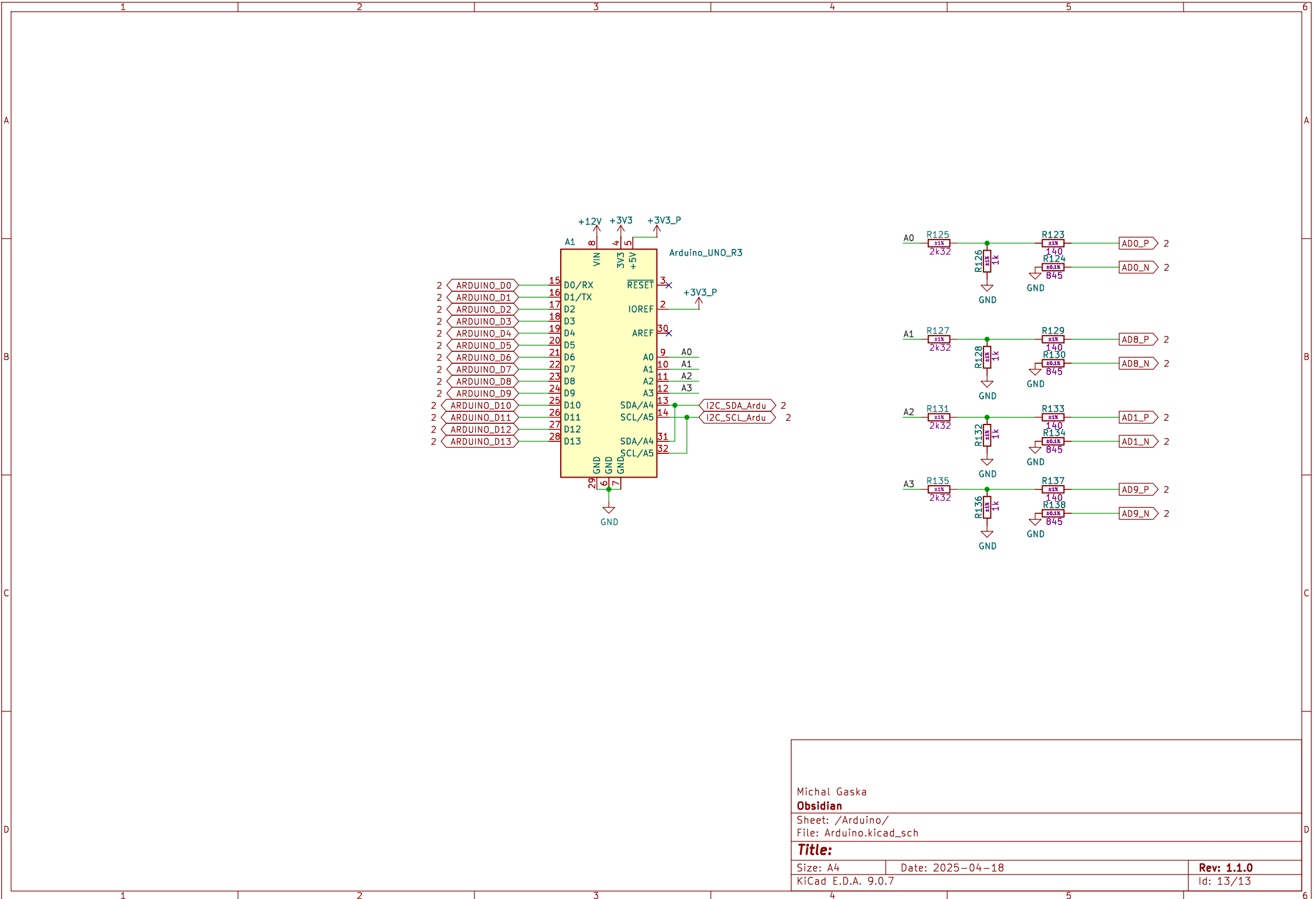

Michal Gaska
Obsidian

Sheet: /Arduino/
 File: Arduino.kicad_sch

Title:

Size: A4 Date: 2025-04-18
 KiCad E.D.A. 9.0.7

Rev: 1.1.0
 Id: 13/13